

NEW

## 3D FAYb Laser Marker

LP-ZV SERIES

FDA  
Conforming to  
FDA regulations

CE

UK  
CA

GB  
Conforming to  
GB 7247.1

Short-pulse fiber laser marker boasting high marking definition and sustainability to meet future needs



# Short Pulse 3D Fiber Laser Marker (with Built-in Camera)

Panasonic Industry's long-lasting, energy-efficient fiber laser markers have further evolved by gaining 1-ns short-pulse marking expressivity and 3D control. The new fiber laser markers offer the same excellent high-output metal marking capability as conventional laser markers and realize high contrast marking and extra small character marking on resin. With a built-in camera, our 3D fiber laser markers contribute to higher productivity.

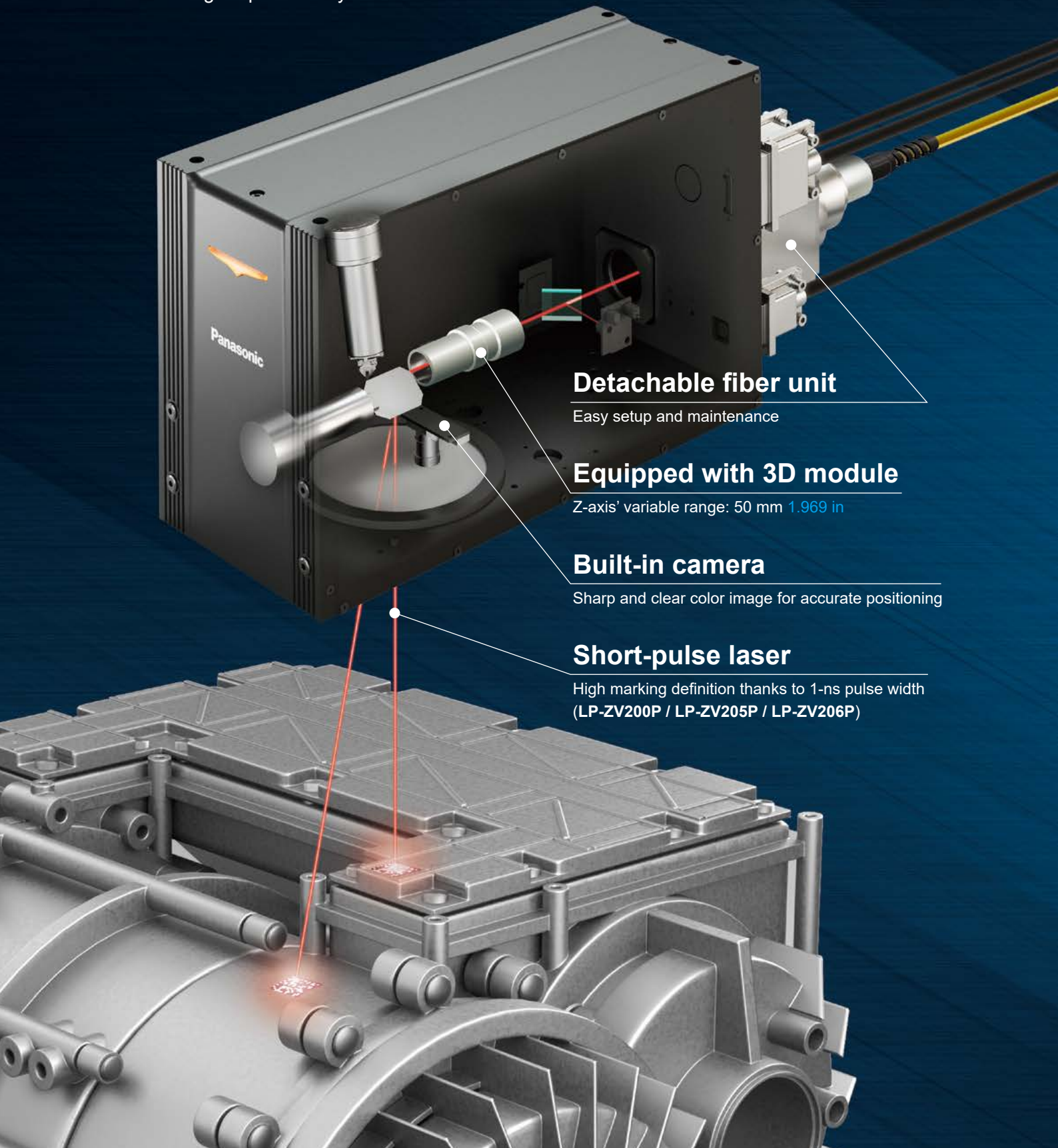

## Detachable fiber unit

Easy setup and maintenance

## Equipped with 3D module

Z-axis' variable range: 50 mm 1.969 in

## Built-in camera

Sharp and clear color image for accurate positioning

## Short-pulse laser

High marking definition thanks to 1-ns pulse width  
(LP-ZV200P / LP-ZV205P / LP-ZV206P)

## Product features

1

### Reduced CO<sub>2</sub> emissions and high marking definition

The energy-efficient fiber oscillation system and short-pulse marking with a pulse duration of 1 ns achieve reduced CO<sub>2</sub> emissions and high marking definition.

P.4~

2

### Improved productivity

The industry's top-class\* marking field size improves productivity and reduces man-hours required for a setup change.

\* According to our company survey, as of June 2023.

P.7

3

### Reduced installation man-hours and shorter downtimes

The simple marking setting and excellent maintainability reduce man-hours required for installation and operation.

P.8~



## LP-ZV SERIES

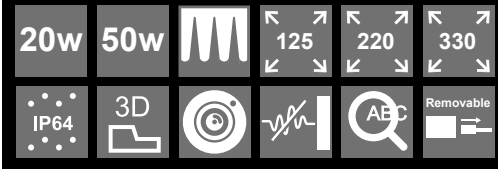

## Examples of marking / processing applications



Automotive secondary battery



Automotive sensor



E-Axle

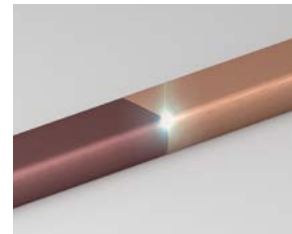

Enamel coating removal



Pre-welding surface processing



Molded resin parts (high contrast marking, stepped surface marking)



Bearing

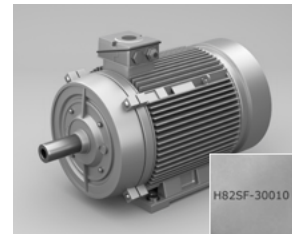

Casting

# Reduced CO<sub>2</sub> emissions and high marking definition

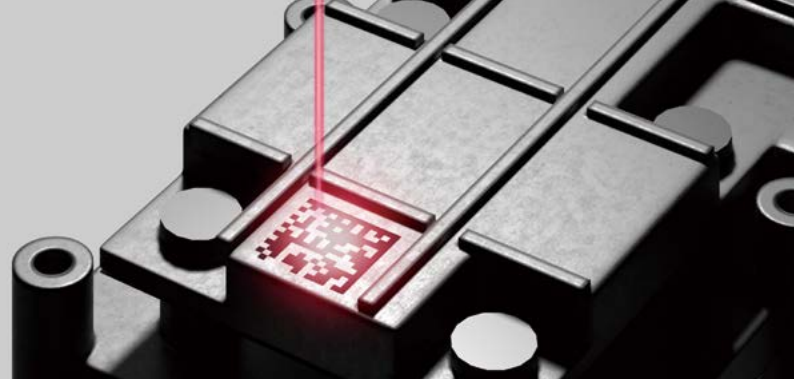

## Panasonic GREEN IMPACT

To deliver “better living” and to achieve the “sustainable global environment,” Panasonic Group announced its long-term environmental vision, “Panasonic GREEN IMPACT,” a commitment to reducing CO<sub>2</sub> emissions generated from its own business operations to net zero by 2030. It also calls for the reduction of the CO<sub>2</sub> emissions from the products used by customers toward 2050. Furthermore, by delivering energy-saving solutions and clean energy technologies to B2B/G customers, we endeavor to reduce CO<sub>2</sub> emissions in our society.

### Short-pulse marking with a pulse duration of 1 ns, combined with low power consumption, reduces CO<sub>2</sub> emissions and achieves high marking definition.

### CO<sub>2</sub> emissions and electricity cost reduced to about half as compared to other systems

Companies are striving to contribute to SDGs (Sustainable Development Goals) and achieve sustainability. In many cases, a CO<sub>2</sub> emission reduction target is set for each business division. Panasonic Industry has developed a fiber oscillating type laser marker by utilizing its proprietary technologies. Its CO<sub>2</sub> emission is about half of that from a product using a different system (such as YAG system, YVO4 system, etc.). Furthermore, the running cost (cost of electricity) can also be reduced to half. Sustainability and low cost are great advantages, especially for facilities that will be used for many long years to come.

#### Comparison of CO<sub>2</sub> emissions



[Estimation conditions]  
Emission factor: 0.457 kg-CO<sub>2</sub>/kWh, laser marker operation: 8 hours/day, 20 days/month, continuous laser irradiation at 100% laser power

## What is fiber laser?

More than just energy-efficient!  
Mechanism of fiber laser marker

A fiber laser marker system uses an innovative method to output an intense laser beam. It sends a weak laser beam (excitation LD light) produced by the master oscillator through a very thin core fiber containing an element called Yb (ytterbium). This results in the amplification of the light with a certain wavelength, and a strong laser light is produced. Since the laser light is amplified inside the fiber, the light-light conversion efficiency reaches about 50%. By suppressing the heat load, the fiber laser marker uses less electricity and offers longer life, thus contributing to sustainability.

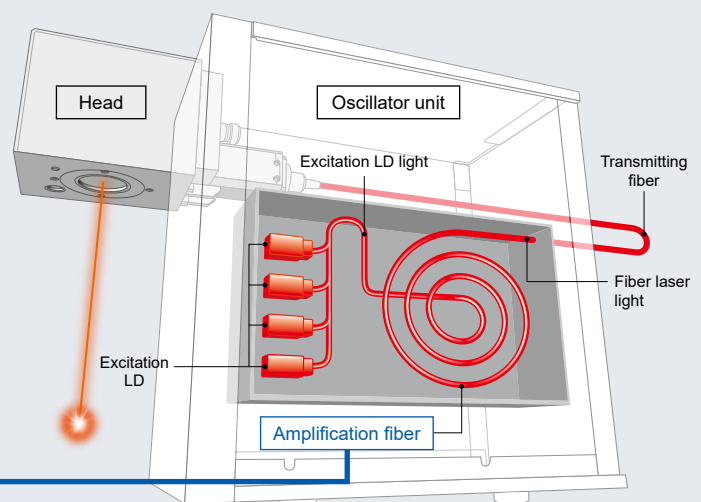
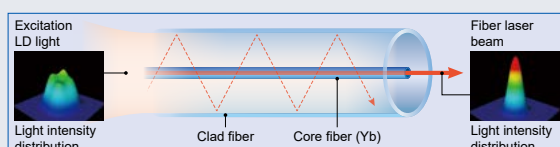

\* Example of fiber laser marker

# High-definition marking by short-pulse laser with a pulse duration of 1 ns (LP-ZV200P / LP-ZV205P / LP-ZV206P)

Panasonic Industry has realized a fiber laser marker system with a short pulse duration of 1 ns by maximizing its original technologies. The new fiber laser marker series minimizes the adverse effects of heat and provides sharp and clear markings.

## Minimal thermal effect

The short-pulse laser causes minimal thermal effect on the workpiece, so scorching, discoloration or deformation by heat is minimized. This allows high contrast marking on devices with ICs and thin metal parts that must not be exposed to high temperatures as well as on resin. The pulse duration is variable, so the most suitable marking condition can be set according to each material type.

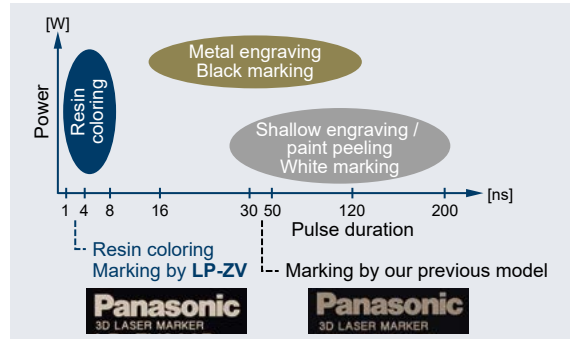

## Takt time reduction and high-quality marking

As shown on the right, high-frequency short-pulse laser oscillation achieves marking / processing without any gap between the laser beam dots even when the laser light scans at high speed. This contributes to the reduction of marking / processing takt times and the improvement of marking quality.

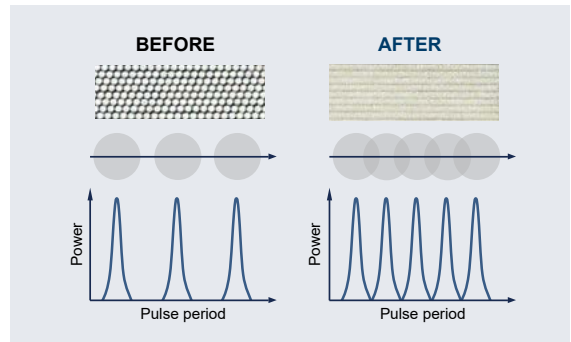

## Clear marking with sharp edges

The short-pulse laser minimizes thermal effect while the high-frequency oscillation achieves clear marking of extremely small and fine characters. Shallow engraving results in easy-to-see white markings and code sections with sharp and clear edges.

This contributes to the excellent visibility of small characters and stable scanning of two-dimensional codes.

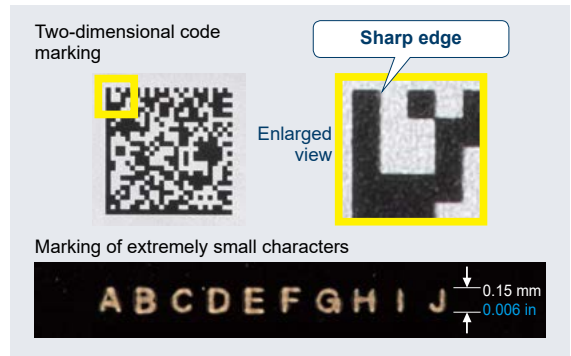

# High-output 52-W\* type suitable for deep engraving and takt time reduction (LP-ZV500P / LP-ZV505P / LP-ZV506P)

\*Oscillator average output

It generally requires a long time to mark a two-dimensional code or to perform deep engraving in a casting process or the like. These laser marker models reduce the marking / processing times and offer enhanced cycle time follow-up performance.

Before surface treatment process

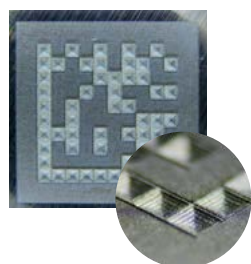

After surface treatment process

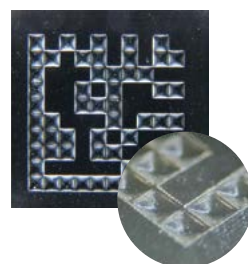

\* The above photos show an image of deep engraving. They do not represent practical conditions.

## Reference Marking examples

The LP-ZV series short-pulse laser markers provide improved marking quality and speed on a variety of materials, including high contrast marking on resin.

The following shows examples of markings.

\*Marking results vary depending on the surface conditions of the materials.



**Panasonic**  
3D LASER MARKER  
LP-ZV200P  
ABCDE1234567890

### Marking conditions

- Two-dimensional code: Data matrix  
(Overall size: 6.24 × 6.24 mm **0.246 × 0.246 in**,  
cell size: 0.24 × 0.24 mm **0.009 × 0.009 in**)
- Character size: 1.8 mm **0.071 in** in height  
(Characters ABCDE1234567890)

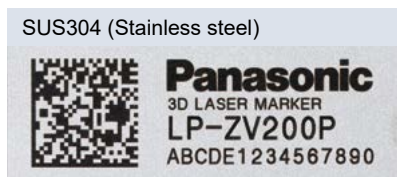

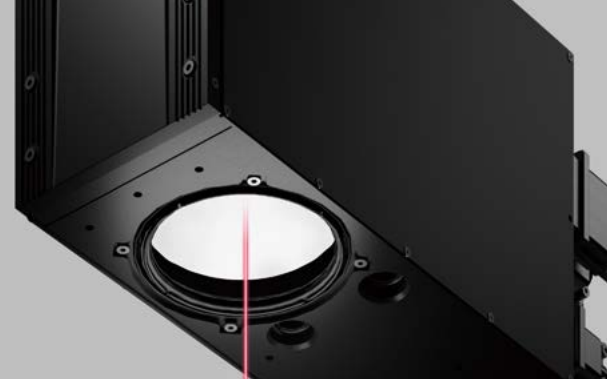

## The industry's top-class\* marking field size improves productivity and reduces man-hours required for a setup change.

\* According to our company survey, as of June 2023.

### Wide marking field of 330 × 330 mm 12.992 × 12.992 in (LP-ZV206P / LP-ZV506P)

Conventionally, markings on large workpieces or on workpieces made with multi-cavity molds required multiple marking operations. The wide marking field enables large size marking in a single marking operation. This not only improves productivity but also reduces the number of required units or simplifies the facility construction to contribute to cost reduction.

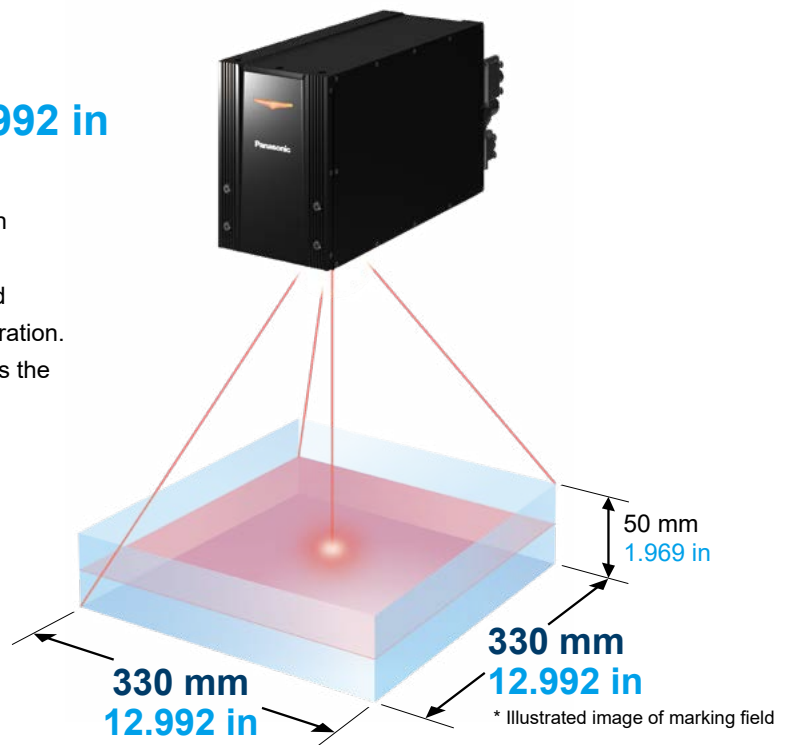

### Variable Z axis to provide a wide range of 50 mm 1.969 in

The Z-axis stroke mechanism controls the laser beam focus in the Z direction so that the focal distance can be set within a wide range of 50 mm 1.969 in. This results in beautiful markings on stepped surfaces, inclined surfaces, spherical surfaces, etc. without blurriness or distortion.

The wide range also eliminates the need for a setup change when workpieces with different heights are sent on the same line, so production of additional models can be easily handled.

#### Variable control of focal distance by Z-axis stroke

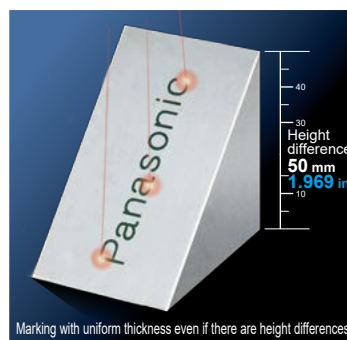
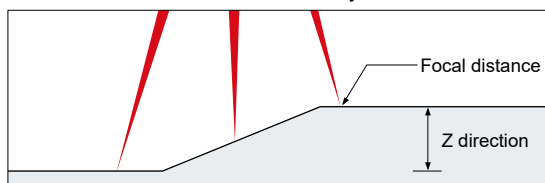

# Reduced installation man-hours and shorter downtimes

Simple marking setting and excellent maintainability reduce man-hours required for installation and operation.

Software to support marking / processing operations  
Laser Marker NAVI smart

Positioning

Setting

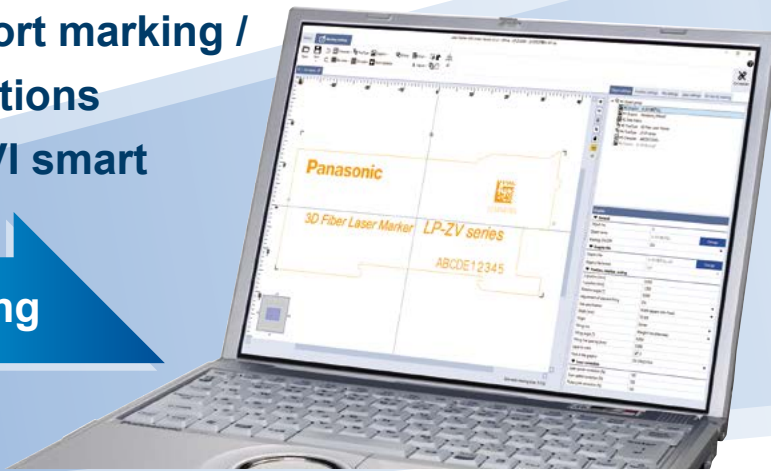

## Easy three-step setting

(1) Lay out the character strings and figures to engrave.

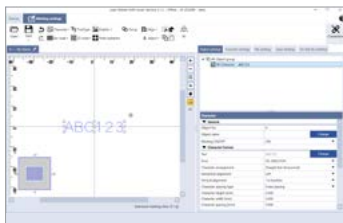

(2) Set the laser irradiation condition.



(3) Start laser irradiation for test marking.



## Navigating the user to the best marking result

### Smart condition setting function



The knowhow of setting marking conditions such as laser power, scan speed and pulse frequency is packed in the software. The software lets the user select desired marking condition from the 15 material types with a one-touch operation.



Iron, stainless steel (shallow engraving)



Iron, stainless steel (deep engraving)

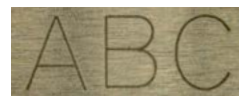

Aluminum (deep engraving)



ABS (white)



PC (white)



PP (black)



## NEW Built-in camera for positioning

Positioning can be performed while viewing the marking / processing data created using the **Laser Marker NAVI smart** software and the image captured by the built-in camera in the head on the same screen. Compared with the conventional red guide laser indication, the color image allows easier confirmation of positioning. Furthermore, the internal light in the head enables positioning even in a dark place such as the inside of a machine.



Marking



### Open network connectivity (option)

By using the industrial network unit\*, the laser marker can be connected to EtherNet/IP or PROFINET for entering the marking and laser light settings via open network.

\* EtherNet/IP unit (**LP-ANW10**) and PROFINET unit (**LP-ANW11**) are available as options.

\* EtherNet/IP is a registered trademark of ODVA (Open DeviceNet Vendor Association, Inc.).

\* PROFINET is a registered trademark of PROFIBUS & PROFINET INTERNATIONAL.

### Automatic update function

The main body has a built-in counter and clock so that the characters to be engraved can be automatically updated. The lot marking function replaces the counter value, date and time with desired character strings. Sequential numbers used as product serial numbers can be generated by the laser marker's internal function alone.

### Display of estimated marking time

The approximate marking / processing time is calculated based on the entered marking data and laser light condition and displayed. When creating setting data off-line, it is possible to calculate the takt time without operating the machine.

### TrueType fonts

The TrueType font set with the **Laser Marker NAVI smart** software can be set directly in the laser marker so that the marking is engraved in that font.

### Touch-panel console (option)

Marking conditions and marking details can be easily set, checked and changed without bringing the PC to the worksite. The touch-panel console (**LP-ADP50**) developed exclusively for laser markers is available as an option. This console can be held by hand or mounted on equipment. It is ergonomically designed for easy operation.

\* The optional function extension board (**LP-AEB10**) is required for connection.

## Fan-less with IP64 ingress protection for reliable operation even in harsh environments

The fan-less structure prevents the entry of water and dust into the head for trouble-free operation.



### Fiber unit attachment / detachment mechanism

In the case of a conventional product with inseparable controller and head unit, the head unit weighing more than 10 kg must be handled manually during installation and for maintenance. The fiber unit attachment / detachment mechanism allows removal of the fiber unit from the head. It contributes to the reduction of man-hours required for installation and maintenance.

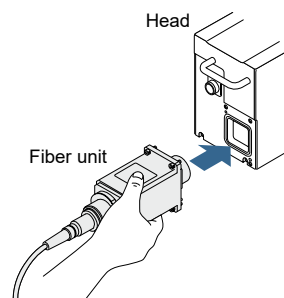

### Controller with superb noise resistant design

The controller features noise suppression parts to offer superb resistance to noise. It responds to a broader range of frequency than the previous model and further reduces the noise level. The new controller prevents problems caused by unexpected electrical noise.

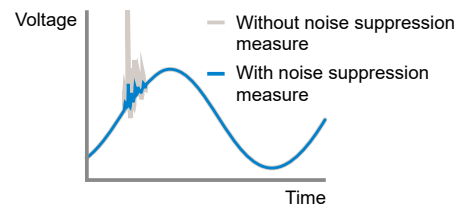

### Display of communication history

The record of serial communications between the laser marker and external device can be displayed. This contributes to the reduction of downtime during facility startup or in case of equipment trouble. The history data can be saved in a CSV file.

Date/time	Interface	PLCestLM	File No.	Command message
2022-08-16 07:33:37.563	Ethernet	←	0208	[ACK]00[CR]
2022-08-16 07:33:40.606	Ethernet	→	0208	[STX]ALCR[CR]
2022-08-16 07:33:40.607	Ethernet	←	0208	[STX]ALCA+038.910,-005.035,+000.000,+179.930.00[CR]
2022-08-16 07:35:37.479	Ethernet	→	0208	[STX]RSM5[CR]
2022-08-16 07:35:37.480	Ethernet	←	0208	[STX]RSMN[CR]
2022-08-16 07:36:04.946	Ethernet	→	0208	[STX]ALCR[CR]

### Marking energy / laser power measuring function

Using the built-in power monitor, the marking energy for each marking operation can be automatically measured and the threshold value judged, or the laser output can be measured for the detection or correction of output decrease during maintenance. The history of output measurements and corrections can be saved in a TSV file for convenient use in planning a maintenance schedule. (Provided in LP-ZV500P / LP-ZV505P / LP-ZV506P)



### Operating data / periodic maintenance notification setting

Operating data such as laser irradiation time and the number of shutter operating times can be checked. A function to notify maintenance need according to operating conditions is provided. This function is useful for planning maintenance.

Type	Unit	Reference cycle for maintenance		
Controller operating time (h)	117	—		
Laser pumping time (h)	17	—		
Laser radiation time (h)	53	30000		
Number of shutter cycles	1192	2000000		
Number of power-on times	304	—		
Controller fan operating time (h)	117	Test		
Battery status for system check	Normal	—		
Number of marking processes	627	—		
Number of switching cycles of INTERLOCK contactor	605	Test	1000000	

Type	Announcement	Next maintenance	Drive	Change
Air filter replacement	✓	In 300 hours of controller operating time	Drive	Change
Laser emission port cleaning	✓	In 24 hours of controller operating time	Drive	Change

## Reset time of less than 1 second. The redundant interlock circuits ensure added safety and improves productivity.



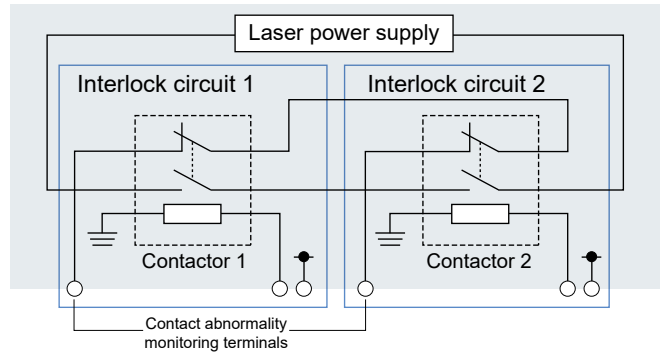

The laser marker features the redundant interlock circuits with contactors. The circuits reliably cut off the laser power supply should an abnormality occur. The laser excitation time is less than one second, thus contributing to productivity improvement while ensuring added safety. Furthermore, various safety enhancement functions, such as wire disconnection detection and erroneous irradiation detection, are provided.



## Interchangeable with Panasonic Industry's conventional models

The **LP-ZV** series laser markers are interchangeable<sup>\*1</sup> with Panasonic Industry's conventional models. They can replace previous models with minimal man-hours. Not only the mounting position but also marking data and communication commands are interchangeable.

\*1: Marking quality, operation, etc. must be checked in advance.

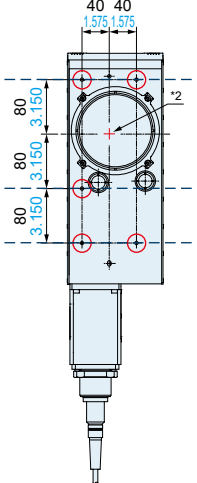
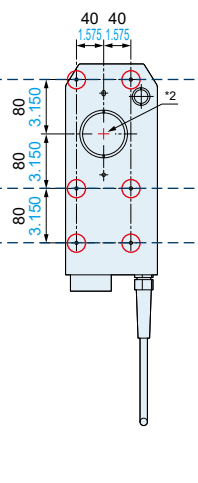
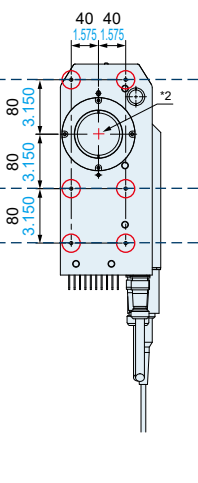
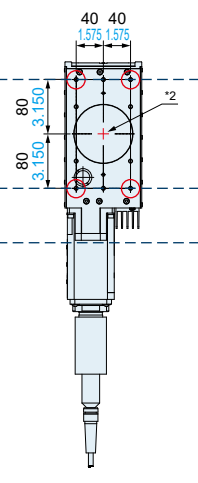
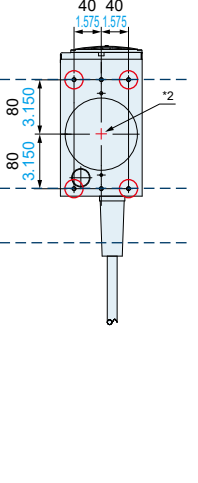
	LP-ZV series	Conventional model				
Series name	 <b>3D FAYb laser marker LP-ZV SERIES</b>	 <b>3D-control FAYb laser marker LP-Z SERIES</b>	 <b>High-output 3D-control FAYb laser marker LP-M SERIES</b>	 <b>High-output FAYb laser marker LP-S/SW SERIES</b>	 <b>FAYb laser marker LP-V15U SERIES</b>	
Interchangeability						
	Average output for marking	17 W / 42 W	13 W / 25 W <sup>*3</sup>	16 W / 40 W	17 W / 42 W	12 W <sup>*3</sup>
	Setting file	Interchangeable	Interchangeable	Interchangeable	Interchangeable	Interchangeable <sup>*4</sup>
	Communication	Interchangeable	Interchangeable	Interchangeable	Interchangeable	Interchangeable

\*2: Center of marking field

\*3: In the case of **LP-Z** series and **LP-V15U** series, the value indicates the average output of the laser oscillator unit.

\*4: Evaluate the marking quality prior to full-fledged installation. Regarding the file conversion method, please contact our sales representative.

# Excellent maintainability to ensure many years of safe operation

## Extensive maintenance parts and a wider range of user maintenance

### Routine maintenance

When using the laser marker in an environment with a large amount of oil mist or dust, it is recommended to wipe the protective glass on the laser emission port of the laser marker head lightly with a soft cloth. Also, clean the air filters and exhaust vents of the oscillator unit and controller as well as the cooling fans in the controller.

#### Cleaning the protective glass on the laser emission port

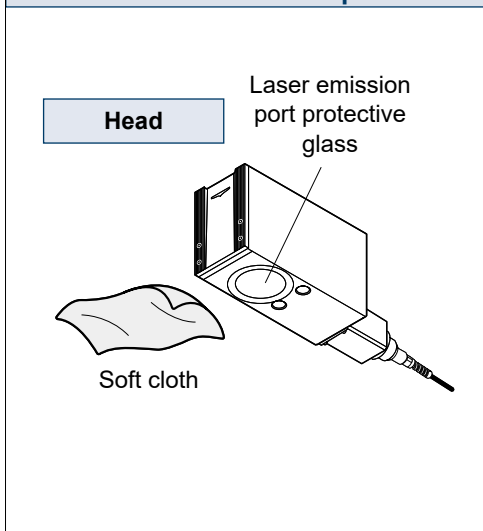

#### Cleaning the air filters, exhaust vents and cooling fans

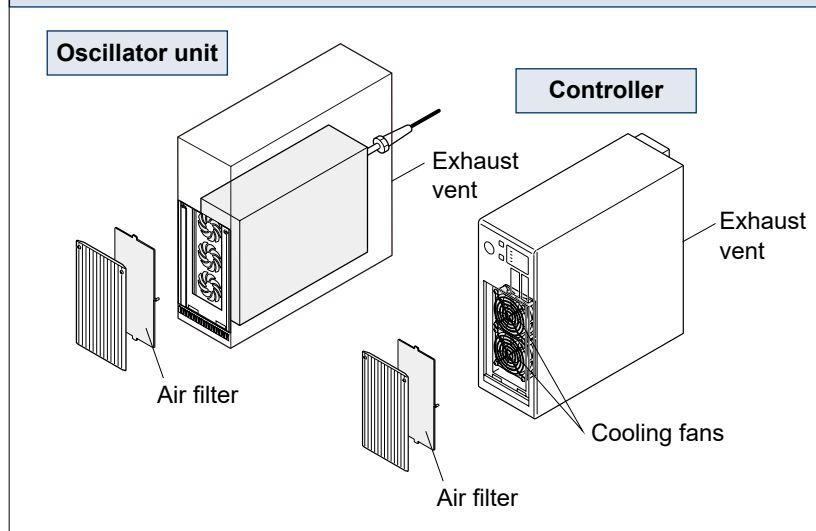

### Limited-life parts and consumables replaceable by customer

It is recommended to replace the physically moving drive parts, parts adhered with oil mist or dust, and consumables periodically (once every several years).

The maintenance parts are designed for easy replacement by the user.

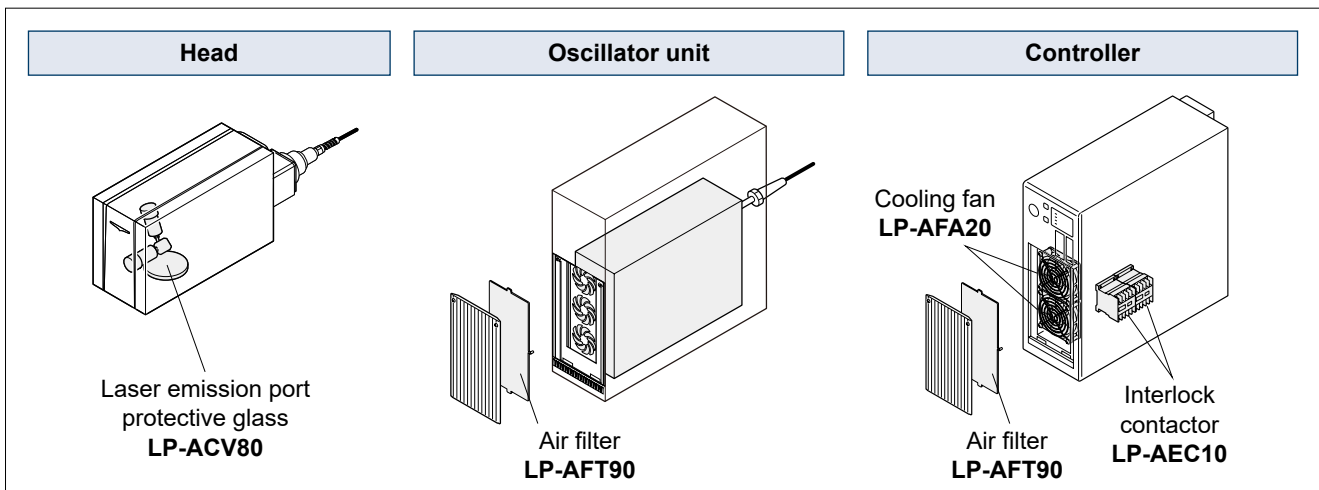

## Manufacturer's services and support directly to users

### Services



#### **Before anything, please contact us.**

If you have any questions or need further information, please feel free to contact our dealer near you.

<https://industrial.panasonic.com/ac/e/salesnetwork/index.jsp>



#### **Proposal of the most suitable model**

We propose the most suitable model for your marking / processing need, cycle time and budget based on our extensive experience.



#### **Proposal of installation of laser marker to equipment**

If you are planning to install a laser marker to your equipment, we discuss about equipment specifications and the communication specifications for communicating with the laser marker.



#### **Free test and test report**

Using workpieces borrowed from your company, we conduct a marking / processing test for free. We will submit marking samples together with the test report.

### Support



#### **Attendance to operation commencement, provision of operating instruction and guidance**

We provide support to the commencement of equipment operation and give operating instructions to operators if so requested by the customer.



#### **Post-installation support**

We can respond to your maintenance need. For example, we can perform on-site maintenance or replace the installed laser markers with replacement units and conduct detailed inspection and maintenance on the removed units at our service base.

## SPECIFICATIONS

### Optical specifications / scanning specification

Model No.	LP-ZV200P	LP-ZV500P	LP-ZV205P	LP-ZV505P	LP-ZV206P	LP-ZV506P
Scanning system	Galvano scanning method					
Marking field (X, Y) (Note 1)	125 mm × 125 mm <b>4.921 in × 4.921 in</b>	220 mm × 220 mm <b>8.661 in × 8.661 in</b>	330 mm × 330 mm <b>12.992 in × 12.992 in</b>			
Work distance (Base level ± variable length) (Note 1)	190 mm ± 25 mm <b>7.480 in ± 0.984 in</b>	220 mm ± 25 mm <b>8.661 in ± 0.984 in</b>	330 mm ± 25 mm <b>12.992 in ± 0.984 in</b>			
Scan speed (Note 2) (Note 3)	12,000 mm <b>472.441 in/sec. max.</b>			8,000 mm <b>314.961 in/sec max.</b>		
Applicable line speed (Note 2)	170 m <b>557.743 ft/min max.</b>			120 m <b>393.701 ft/min. max</b>		
Character height / width (Note 2)	0.100 mm to 125.000 mm <b>0.004 in to 4.921 in</b>		0.100 mm to 220.000 mm <b>0.004 in to 8.661 in</b>		0.100 mm to 330.000 mm <b>0.004 in to 12.992 in</b>	

### Laser specifications / Other basic specifications

Model No.	LP-ZV200P	LP-ZV205P	LP-ZV206P	LP-ZV500P	LP-ZV505P	LP-ZV506P	
Applicable regulations and certifications	FDA Regulations, CE Marking [Machinery Directive (Declaration of Incorporation), EMC Directive, RoHS Directive], UKCA Marking [Supply of Machinery (Safety) Regulations (Declaration of Incorporation), EMC Regulations, RoHS Regulations], Chinese Standard GB 7247.1						
Marking laser	Laser type	Yb: Fiber laser, Wavelength: 1,064 nm <b>0.0419 mil</b> , Class 4 laser					
	Oscillator average output	20 W			52 W		
	Average output for marking (Note 4)	17 W (±5%)			42 W (±5%)		
	Laser oscillation system	Pulsed oscillation					
	Pulse duration	1 ns, 4 ns, 8 ns, 16 ns, 30 ns, 50 ns, 120 ns, 200 ns (8-step switching)			150 ns		
	Pulse cycle (Note 5)	0.5 μs to 500 μs			2 μs to 20 μs		
Guide laser, laser pointer	Red semiconductor, Wavelength: 655 nm <b>0.0258 mil</b> , Class 2 laser, Maximum output: 1 mW or less						
Beam stop	One shutter is equipped inside of head						
Workpiece shape	Plane, stepped, cylinder, cone, sphere						
Workpiece status	Stationary object, Moving object						
No. of registerable files	10,000 files						
No. of marking data pieces (No. of registerable objects)	2,000 objects/file						
Marking data	Character	West-European alphabet (A to Z, a to z, Latin-1 characters), numeric, symbol, user defined characters (up to 50 characters can be set) Japanese characters: Katakana, Hiragana, Kanji (JIS level-1 and level-2) Simplified Chinese characters: GB 2312 level-1 and level-2					
	TrueType	TrueType fonts stored in the PC with <b>Laser Marker NAVI smart</b> installed (Note 6)					
	Bar code	CODE39, CODE93, CODE128 (GS1-128), ITF, NW-7, EAN/UPC/JAN GS1 DataBar Limited, GS1 DataBar Stacked, GS1 DataBar Limited CC-A, GS1 DataBar Stacked CC-A					
	2D code	QR code, Micro QR code, iQR code, Data Matrix, GS1 Data Matrix, PDF417					
	Graphic file (Note 7)	VEC, DXF, HPGL, BMP, JPEG, AI, EPS					
	Point and shapes	Point radiation, line, circle, arc					
Character arrangement	Straight line, Arc, Proportional, Justify						
I/O port	I/O terminal block (40-pins), I/O connector (40-pins), Displacement sensor terminal block (Note 8)						
Communication interface	EIA-RS-232C, Ethernet, EtherNet/IP (Note 9), PROFINET (Note 9)						
Dedicated software (Note 10)	<b>Laser Marker NAVI smart</b> , Logo Data Editing Software, <b>ExportVEC</b> , Font Maker						
Supported OS (Note 11)	Windows® 11 Pro 32bit / 64bit, Windows® 10 Pro 32bit / 64bit						
Laser marker NAVI smart connection method	USB, Ethernet						
Laser marker NAVI smart display language	Japanese, English, Simplified Chinese, Traditional Chinese, German, Korean						
Required time for system startup	Approx. 10 seconds						
Required time for laser excitation	Approx. 1 to 2 second max.						
Power voltage	90 V to 132 V AC or 180 V to 264 V AC (including ±10% voltage fluctuations), Frequency: 50/60 Hz (Note 12)						
Power consumption (Consumption current) (Note 13)	At 100 V AC	320 VA or less (3.6 A or less)			510 VA or less (5.7 A or less)		
	At 200 V AC	360 VA or less (2.0 A or less)			520 VA or less (2.9 A or less)		
Grounding method	Direct earth for the head, oscillator unit, and controller respectively						
Cooling method	Head: Natural air-cooling, Oscillator unit: Forced air-cooling, Controller: Forced air-cooling						
Operating ambient temperature (Note 14)	Head	<With laser power setting 46 or more> 0 °C to +36 °C <b>+32 °F to +96.8 °F</b> (Note 15), Storage: -10 °C to +60 °C <b>+14 °F to +140 °F</b>			0 °C to +40 °C <b>+32 °F to +104 °F</b> , Storage: -10 °C to +60 °C <b>+14 °F to +140 °F</b>		
	Oscillator unit	<With laser power setting less than 46> 0 °C to +40 °C <b>+32 °F to +104 °F</b> (Note 15), Storage: -10 °C to +60 °C <b>+14 °F to +140 °F</b>					
	Controller	0 °C to +40 °C <b>+32 °F to +104 °F</b> , Storage: -10 °C to +60 °C <b>+14 °F to +140 °F</b>					
Operating ambient humidity (Note 14)	35 to 85% RH						
Protection degree of head (Note 16)	IP64						
Overvoltage category / Pollution degree	II / 2						
Use location	Indoor; at an altitude of 1,000 m or below						
Fiber cable length	2 m ± 0.2 m <b>6.562 ft ± 0.656 ft</b> , Minimum bent radius 80 mm <b>3.150 in</b>			5 m ± 0.2 m <b>16.404 ft ± 0.656 ft</b> , Minimum bent radius 80 mm <b>3.150 in</b>			
Installation direction	Head: In all directions, Oscillator unit and controller in assembled condition: Vertically or horizontally						
Weight	Head: Approx. 11 kg, Oscillator unit: Approx. 12 kg, Controller: Approx. 12 kg						

- Notes: 1) There is some degree of variation between individual units of the same model.  
 2) The value shown here is the configuration range that can be input. The setting values that can keep the quality of marking or processing vary depending on the setting details and the target materials.  
 3) Depending on the setting data, the available scan speed might be limited.  
 4) Output at processing point with the following settings (at delivery time)  
**LP-ZV200P / LP-ZV205P / LP-ZV206P**: laser power 100, pulse duration 8 ns, and pulse cycle 3.3 μs.  
**LP-ZV500P / LP-ZV505P / LP-ZV506P**: laser power 100, pulse cycle 20 μs.  
 5) In the case of **LP-ZV200P**, **LP-ZV205P** and **LP-ZV206P**, the setting range of the pulse cycle varies according to the pulse duration.  
 6) Some of the languages or character types are not supported by this laser marker. Characters written from right to left such as Arabic or Hebrew, characters based on ligature such as Indian languages cannot be input.  
 7) VEC is a graphic file format dedicated for the laser marker. To use AI or EPS files, convert them to VEC format with the dedicated software "ExportVEC".  
 8) Displacement sensor terminal block is available when the optional expansion board is installed to the controller.  
 9) Available when the optional network unit is installed to the controller.  
 10) The software is available from our Internet website.  
 11) OS versions of which Microsoft has ended support are excluded.  
 12) The frequency switches automatically.  
 13) The typical value of the inrush current at startup is as follows: (Duration time is 10 ms or less.)  
 At 100 V AC: 85 A, At 200 V AC: 170 A  
 14) Common to the controller, oscillator unit and head. No condensation or freezing shall be allowed. If there is a gap between the stored temperature and operating temperature, make sure to have the product get used to the operating ambient temperature gradually prior to use to prevent the dew condensation.  
 15) If the laser power is corrected in system offset or other detailed settings, the allowed temperature is defined with the corrected value.  
 16) The controller and oscillator unit are non-compliant with the ingress protection rating. The ingress protection characteristics of the head are ensured only when the fiber unit, laser emission protection glass, cables and connector covers are installed properly.  
 \* EtherNet/IP is a registered trademark of ODVA (Open DeviceNet Vendor Association, Inc.).  
 \* PROFINET is a registered trademark of PROFIBUS & PROFINET INTERNATIONAL.  
 \* Windows is a registered trademark or trademark of Microsoft Corporation in the United States and/or other countries.

## OPTIONS

### AC power cable

Use the cable that complies with the regulations and standards of the country / region where the product is used.

		Type	Model No.
AC power cable	Rating 125 V AC	PSE standards compatible cable (Japan)	<b>LP-ACA10</b>
	Rating 250 V AC	PSE standards compatible cable (Japan)	<b>LP-ACA11</b>
		CE marking compatible cable (Europe) (Note 1)	<b>LP-ACA12</b>

Note: 1) The plug of the 250 V AC, CE-compliant cable (for Europe) conforms to the following standards.  
VDE, DEMKO, NEMKO, FIMKO, SEMKO, OVE, KEMA, CEBEC

### Touch panel console / Expansion board

Type	Model No.
Touch panel console	<b>LP-ADP50</b>
Expansion board (Note 2)	<b>LP-AEB10</b>

Note: 2) When the expansion board is installed to the controller, the following functions can be used.

- Connect a touch panel console or a commercially available monitor to the laser marker and use it for monitoring and setting during operation.
- The displacement sensor is connected to the laser marker to correct the work distance.

### Industrial network unit

Type	Model No.
Industrial network unit for EtherNet/IP	<b>LP-ANW10</b>
Industrial network unit for PROFINET	<b>LP-ANW11</b>

\* EtherNet/IP is a registered trademark of ODVA (Open DeviceNet Vender Association, Inc.).  
\* PROFINET is a registered trademark of PROFIBUS & PROFINET INTERNATIONAL.

### Maintenance and service parts

Type	Model No.	
Protection glass of laser emission port (for replacement)	<b>LP-ACV80</b>	
Dedicated air filters (for replacement)	Set of 2 for controller / oscillator unit	<b>LP-AFT90</b>
Cooling fans of controller (for replacement)	Set of 2 fans	<b>LP-AFA20</b>
Unit power cable (for replacement)	2 m 6.562 ft type	<b>LP-ACP20-2</b>
	5 m 16.404 ft type	<b>LP-ACP20-5</b>
Signal cable (for replacement)	2 m 6.562 ft type	<b>LP-ACS10-2</b>
	5 m 16.404 ft type	<b>LP-ACS10-5</b>
Connector cover and gasket (for replacement)		<b>LP-ACC11</b>
Contacting unit for Interlock (for replacement)		<b>LP-AEC10</b>

## DIMENSIONS (Unit: mm in)

CAD data can be downloaded from our website

For details, refer to the Setup / Maintenance Guide. The Setup / Maintenance Guide can be downloaded from our website.

### Head

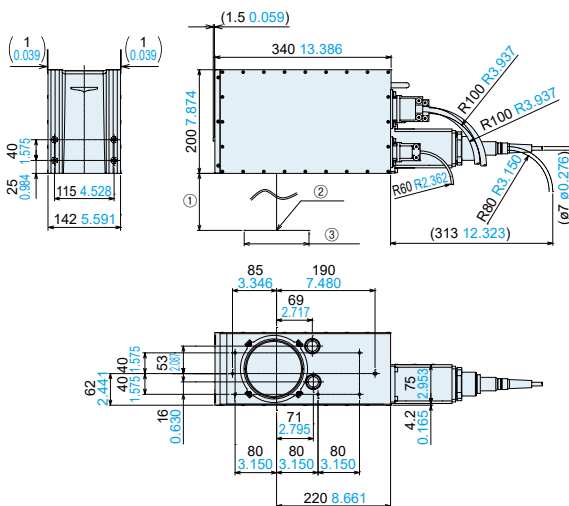

### Fiber unit

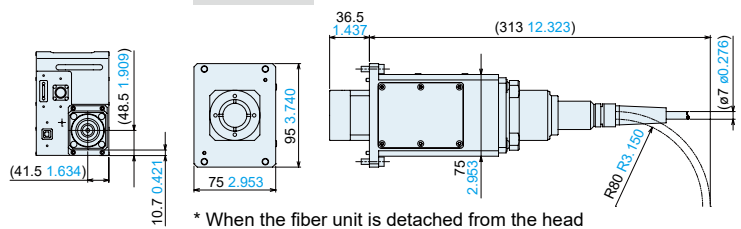

\* When the fiber unit is detached from the head

No.	Description
①	Work distance (Base level ± variable length): LP-ZV200P / LP-ZV500P: 190 mm ±25 mm 7.480 in ±0.984 in LP-ZV205P / LP-ZV505P: 220 mm ±25 mm 8.661 in ±0.984 in LP-ZV206P / LP-ZV506P: 330 mm ±25 mm 12.992 in ±0.984 in
②	Center of marking field
③	Marking field (X, Y): LP-ZV200P / LP-ZV500P: 125 mm × 125 mm 4.921 in × 4.921 in LP-ZV205P / LP-ZV505P: 220 mm × 220 mm 8.661 in × 8.661 in LP-ZV206P / LP-ZV506P: 330 mm × 330 mm 12.992 in × 12.992 in

### Oscillator unit

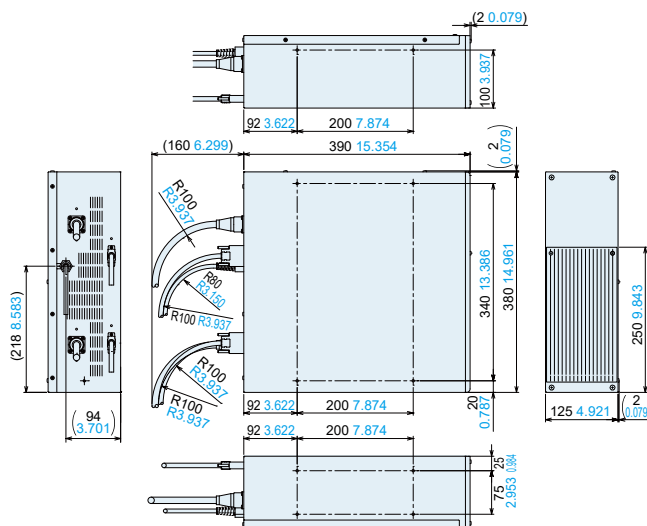

### Controller

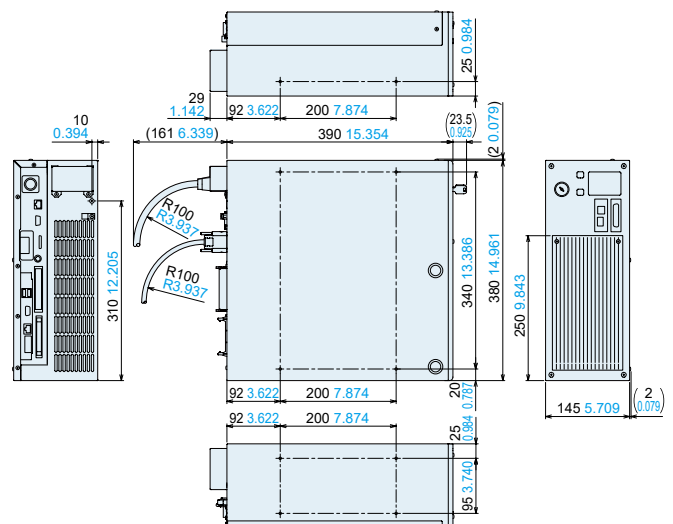

\* The laser marker product is not supplied with an AC power cable. (Optional)

**LP-ADP50**

Touch panel console (Optional)

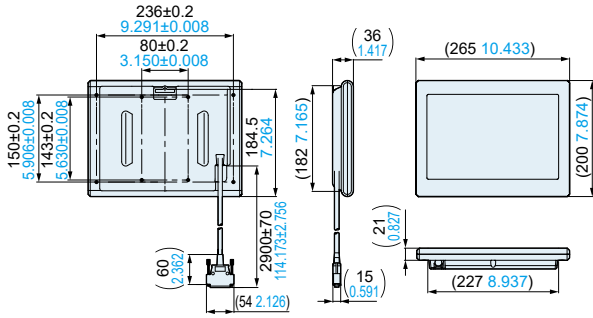

**[Important note]**

**About laser light**

- This product is a Class 4 laser product as defined by the JIS standards. Do not look directly toward the laser light or touch the laser light or its reflections. Be sure to take the required safety measures in accordance with the standards.
- The labels shown at the right are affixed on the product. (The labels are not affixed on the products shown in this catalog.)
- The laser light is an infrared light and invisible to the human eyes. Exercise caution when the laser oscillator is operating.

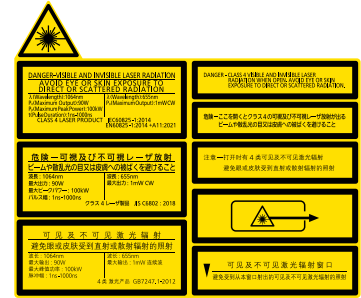

**Use of dust collector recommended**

- Some materials generate a toxic gas or smoke during laser marking, and this may cause adverse effects on the human health or laser marker. In such a case, use a dust collector. For more information, please contact our sales representative.

**Disclaimer**

The applications described in the catalog are all intended for examples only. The purchase of our products described in the catalog shall not be regarded as granting of a license to use our products in the described applications. We do NOT warrant that we have obtained some intellectual properties, such as patent rights, with respect to such applications, or that the described applications may not infringe any intellectual property rights, such as patent rights, of a third party.



**Panasonic Industry Co., Ltd.**  
 Industrial Device Business Division  
 7-1-1, Morofuku, Daito-shi, Osaka 574-0044, Japan  
[industrial.panasonic.com/ac/e/](http://industrial.panasonic.com/ac/e/)